



.....

Barracuda 18LP

.....

Disc Drive

.....

ST39175LW/LC

.....

ST318275LW/LC

.....

Installation Guide

.....

Contents

Preface.....	1
Electrostatic discharge protection	1
Important safety information and precautions.....	2
Wichtige Sicherheitshinweise	4
Regulatory agency compliance.....	7
Seagate Technology support services	9
General description.....	15
Initial setup information	19
Kühlung des Systems	30
Installation des Laufwerkes und Anschluß der Kabel.....	32
LW drives section	40
LC drives section	45

©1997-1999 Seagate Technology, Inc. All rights reserved
Publication Number: 77767527, Rev. B
May 1999

Seagate, Seagate Technology, and the Seagate logo are registered trademarks of Seagate Technology, Inc. Barracuda, SeaFAX, SeaFONE, SeaBOARD, and SeaTDD are either trademarks or registered trademarks of Seagate Technology, Inc. or one of its subsidiaries. All other trademarks or registered trademarks are the property of their respective owners.

No part of this publication may be reproduced in any form without written permission from Seagate Technology, Inc.

Preface

This manual contains information for users of the Seagate® Barracuda 18LP SCSI disc drives. It provides support services, performance specifications, and initial setup information. Additional information is available in the *Barracuda 18LP Product Manual* (part number 77767526). Contact your Seagate sales representative if you need to order this publication.

Note. If any differences exist between specification values in this guide and the product manual, the product manual values are the authoritative values.

Electrostatic discharge protection

Caution. Removal of circuit boards by personnel not performing depot repair will damage components and may void the warranty.

All drive electronic assemblies are sensitive to static electricity, due to the electrostatically sensitive devices used within the drive circuitry. Although some devices such as metal-oxide semiconductors are extremely sensitive, all semiconductors, as well as some resistors and capacitors, may be damaged or degraded by exposure to static electricity.

Electrostatic damage to electronic devices may be caused by the direct discharge of a charged conductor or by exposure to the static fields surrounding charged objects. To avoid damaging drive electronic assemblies, observe the following precautions when installing or servicing the drive:

- Ground yourself to the drive whenever the drive electronics are or will be exposed. Connect yourself to ground with a wrist strap (Seagate part number 12263496). Connection may be made to any grounded metal assembly. As a general rule,

remember that you and the drive electronics must all be grounded to avoid potentially damaging static discharges.

- Turn off the power before removing or installing the DC power cable.
- Do not remove any circuit boards from the drive.
- Never use an ohmmeter on any circuit boards.
- When installing the drive on a carrier or tray, discharge the carrier or tray prior to inserting it into the system.

Important safety information and precautions

Caution. Use forced-air ventilation when bench-testing the drive to ensure proper cooling of drive components.

Use proper safety techniques for safe, reliable operation of this unit.

The procedures in this manual and labels on the unit contain warnings and cautions that must be carefully read and followed to minimize or eliminate the risk of personal injury. The warnings point out conditions or practices that may endanger you or others. The cautions point out conditions or practices that may damage the unit, possibly making it unsafe for use.

Always observe the following warnings and precautions:

- Follow all cautions and warnings in the procedures.
- Use sound safety practices when operating, installing, or removing the unit.
- Use caution when troubleshooting a unit that has voltages present. Turn off power to the unit before removing it.
- Ensure that the internal temperature of the rack or cabinet does not exceed the limits defined for the drive when the drive is mounted in an equipment rack or cabinet. When units are

stacked vertically, pay special attention to the top where temperatures are usually highest.

- Follow the precautions listed above in “Electrostatic discharge protection.”
- Do not remove any circuit boards from the drive. Return the entire drive for depot repair if any circuit board is defective. Removal of circuit boards by personnel not performing depot repair will damage components and may void the warranty.
- Do not remove the head and disc assembly (HDA) from the drive. Return the entire drive for depot repair if the HDA is defective.
- Do not attempt to disassemble the HDA. It is not field repairable. If the sealed HDA is opened by personnel not performing depot repair, this will damage components and void the warranty.

As a component, this drive is designed to be installed and operated in accordance with UL1950, EN60950, CAN/CSA C22.2 950-95, and VDE0805.

Seagate takes all reasonable steps to ensure that its products are certifiable to currently accepted standards. Typical applications of these disc drives include customer packaging and subsystem design. Safety agencies conditionally certify component assemblies, such as the Barracuda disc drive, based on their final acceptability in the end-use product. The subsystem designers are responsible for meeting these conditions of acceptability in obtaining safety-regulatory agency compliance in their end-use products and for certifying where required by law. A necessary part of meeting safety requirements is the provision for overcurrent protection on drive SELV supply voltages.

This unit is a component part and as such is not meant to comply with FCC or similar national requirements as a stand-alone unit. Engineering radiated emissions test results are available through the Seagate Safety Department to assist the subsystem designer.

Wichtige Sicherheitshinweise

Vorsicht. Beim Testen des Laufwerks auf dem Prüftisch ist Fremdbelüftung vorzusehen, um eine ausreichende Kühlung der Laufwerkkomponenten sicherzustellen.

Verwenden Sie geeignete Sicherheits- um den sicheren, zuverlässigen Betrieb dieser Einheit zu gewährleisten.

Die Verfahren in diesem Handbuch und die Aufkleber auf dem Gerät enthalten Warn- und Vorsichtshinweise. Diese Hinweise sind sorgfältig durchzulesen und zu beachten, um das Risiko von Verletzungen auf ein Mindestmaß zu beschränken oder ganz zu vermeiden. Die Warnhinweise machen auf Situationen oder Praktiken aufmerksam, die Sie oder andere gefährden könnten. Die Vorsichtshinweise machen auf Situationen oder Praktiken aufmerksam, die die Einheit beschädigen können, so daß deren Gebrauch mit Risiko behaftet ist.

Die Warn- und Vorsichtshinweise sind nicht allumfassend! Es ist uns einfach nicht möglich, alle Wartungsmethoden oder die eventuellen Risiken jeder Methode zu kennen, zu beurteilen und Sie entsprechend zu beraten. Aus diesem Grund haben wir auf eine derartige umfassende Beurteilung verzichtet. Falls Sie ein hier nicht beschriebenes Verfahren oder Werkzeug verwenden, stellen Sie zuerst sicher, daß das gewählte Verfahren weder Ihre persönliche Sicherheit noch die Leistung der Einheit gefährdet.

Beachten Sie in jedem Fall die folgenden Warn- und Vorsichtshinweise:

- Beachten Sie alle Warn- und Vorsichtshinweise in diesem Handbuch.
- Treffen Sie beim Betrieb, bei der Installation oder bei der Entfernung der Einheit angemessene Sicherheitsvorkehrungen.
- Wenn eine Einheit unter Spannung steht, gehen Sie bei der Fehlerdiagnose besonders vorsichtig vor. Schalten Sie die Einheit aus, bevor Sie mit den Installations- und Entfernungsarbeiten beginnen.
- Wenn das Laufwerk in einem Einbaugestell oder Gehäuse montiert ist, sorgen Sie dafür, daß die Temperatur im Inneren des Gestells oder Gehäuses die für das Laufwerk vorgegebenen Grenzwerte nicht übersteigt. Wenn Einheiten vertikal übereinander betestigt werden, achten Sie besonders auf den oberen Stapelbereich, da dort die Temperatur gewöhnlich am höchsten ist.
- Befolgen Sie die oben unter "Electrostatic Discharge Protection" angegebenen Sicherheitsmaßnahmen.
- Nehmen Sie keine Platinen aus dem Laufwerk. Wenn eine Platine defekt ist, muß das gesamte Laufwerk zur Reparatur eingeschickt werden. Die Herausnahme von Platinen durch andere Personen als die für die werkseitige Reparatur zuständigen kann zu einer Beschädigung der Komponenten und Erlöschen des Garantieanspruchs führen.
- Die vormontierte Kopf- und Festplatteneinheit (HDA) nicht aus dem Laufwerk nehmen! Falls die HDA beschädigt ist, schicken Sie das gesamte Laufwerk zur Reparatur ein.

- Die HDA ist nicht vor Ort reparierbar und darf nicht auseinandergenommen werden! Öffnen der versiegelten HDA durch andere Personen als die für die werkseitige Reparatur zuständigen hat eine Beschädigung der Komponenten und Erlöschen des Garantieanspruchs zur Folge.

Als Teilkomponente ist dieses Laufwerk für die Installation und den Betrieb in Übereinstimmung mit UL 1950, EN60950, CAN/CSA C22.2 950-95 und VDE0805 vorgesehen.

Seagate ist ständig bemüht, die Zulassungsfähigkeit von Seagate-Produkten im Rahmen der gegenwärtig geltenden Standards zu gewährleisten. Zu den typischen Anwendungen dieser Festplattenwerke zählen Systemeinstbau durch den Kunden und die Konstruktion von Untersystemen. Sicherheitsbehörden gewähren eine bedingte Zulassung für Komponenten wie das Barracuda-Festplattenlaufwerk vorbehaltlich der endgültigen Zulassung im Endprodukt. Designer von Untersystemen sind dafür verantwortlich, die Voraussetzungen für die Einhaltung sicherheits- oder aufsichtsbehördlicher Vorschriften in ihren Endprodukten und - falls gesetzlich vorgeschrieben - für die Zulassung zu schaffen. Eine Grundvoraussetzung zur Einhaltung der Sicherheitsanforderungen ist die Bereitstellung eines Überlastschutzes für die SELV-Versorgungsspannungen des Laufwerks.

Dieses Gerät ist eine Baugruppe und unterliegt als solche nicht den Anforderungen der FCC oder ähnlicher nationaler Behörden für eigenständige Geräte. Technische Testergebnisse zu elektromagnetische Strahlung sind für Designer von Untersystemen auf Anfrage von der Seagate-Sicherheitsabteilung erhältlich.

Regulatory agency compliance

Electromagnetic susceptibility

As a component assembly, the drive is not required to meet any susceptibility performance requirements. It is the responsibility of those integrating the drive within their systems to perform those tests required and design their system to ensure that equipment operating in the same system as the drive or external to the system does not adversely affect the performance of the drive. See Table 2, DC power requirements.

Electromagnetic compliance

Seagate uses an independent laboratory to confirm compliance to the directives/standard(s) for CE Marking and C-Tick Marking. The drive was tested in a representative system for typical applications. The selected system represents the most popular characteristics for test platforms. The system configurations include:

- 486, Pentium, and PowerPC microprocessors
- 3.5-inch floppy disc drive
- Keyboard
- Monitor/display
- Printer
- External modem
- Mouse

Although the test system with this Seagate model complies to the directives/standard(s), we cannot guarantee that all systems will comply. The computer manufacturer or system integrator shall confirm EMC compliance and provide CE Marking and C-Tick Marking for their product.

Electromagnetic compliance for the European Union

If this model has the CE Marking it complies with the European Union requirements of the Electromagnetic Compatibility Directive 89/336/EEC of 03 May 1989 as amended by Directive 92/31/EEC of 28 April 1992 and Directive 93/68/EEC of 22 July 1993.

Australian C-Tick

If this model has the C-Tick Marking it complies with the Australia/New Zealand Standard AS/NZS3548 1995 and meets the Electromagnetic Compatibility (EMC) Framework requirements of Australia's Spectrum Management Agency (SMA).

Seagate Technology support services

Online Services

Internet

For online information about Seagate products, visit www.seagate.com or e-mail your disc or tape questions to:

Presales Support:

Disc: http://www.seagate.com/support/email/email_presales.shtml or DiscPresales@Seagate.com

Tape: http://www.seagate.com/support/email/email_tape_presales.shtml or
Tape_Sales_Support@Seagate.com

Technical Support:

Disc: http://www.seagate.com/support/email/email_disc_support.shtml or DiscSupport@Seagate.com

Tape: http://www.seagate.com/support/email/email_tape_support.shtml or TapeSupport@Seagate.com

SeaBOARD[®] is a computer bulletin board system that contains information about Seagate disc and tape drive products and is available 24 hours daily. Set your communications software to eight data bits, no parity and one stop bit (8-N-1). This service is available worldwide.

Automated Services

SeaFONE[®] (1-800-SEAGATE) is Seagate's toll-free number (1-800-732-4283) to access our automated self-help services. Using a touch-tone phone, you can find answers to service phone numbers, commonly asked questions, troubleshooting

tips and specifications for disc drives and tape drives 24 hours daily. International callers can reach this service by dialing +1-405-936-1234.

SeaFAX® is Seagate's automated FAX delivery system. Using a touch-tone phone, you can obtain technical support information by return FAX 24 hours daily. This service is available worldwide.

Presales Support

Our Presales Support staff can help you determine which Seagate products are best suited for your specific application or computer system.

Seagate Express

You can purchase select tape products and tape accessories through Seagate Express 24 hours daily by calling 1-800-531-0968 or by faxing your order to: +1-972-481-4812.

Technical Support

If you need help installing your drive, consult your dealer. Dealers are familiar with their unique system configurations and can help you with system conflicts and other technical issues. If you need additional help, you can talk to a Seagate technical support specialist. Before calling, note your system configuration and drive model number (ST####).

SeaTDD™(+1-405-936-1687) is a telecommunications device for the deaf (TDD). You can send questions or comments 24 hours daily and exchange messages with a technical support specialist from 8:00 A.M. to 12:15 P.M. and 1:30 P.M. to 6:00 P.M. (central time) Monday through Friday.

Customer Service (CSO)

Warranty Repair

Seagate offers worldwide customer support for Seagate drives. Seagate direct OEM, Distribution and System Integrator customers should contact their Seagate service center representative for warranty information. Other customers should contact their place of purchase.

Authorized Service Centers

If you live outside the US, you can contact an Authorized Service Center for service or repair.

USA/Canada/Latin America Support Services

Presales Support

Disc: 1-877-271-3285 or FAX: +1-405-936-1683
+1-405-936-1210

Tape: 1-800-626-6637 or FAX: +1-714-641-2410
+1-714-641-2500

Technical Support (SeaFONE)

1-800-SEAGATE or +1-405-936-1234 (for specific product phone number)

FAX: *Disc:* +1-405-936-1685; *Tape:* +1-405-936-1683

SeaFAX 1-800-SEAGATE

SeaTDD +1-405-936-1687

SeaBOARD *Disc:* +1-405-936-1600; *Tape:* +1-405-936-1630

Warranty Repair

USA	1-800-468-3472	FAX: +1-405-949-6740
Mexico and Latin America	+1-405-949-7758	FAX: +1-405-949-6738

Authorized Service Centers

Brazil

MA Informatica +55-21-516-6649 FAX: +55-21-516-5280

Canada

*Memofix*¹ +1-905-660-4936 FAX: +1-905-660-4951

*Adtech*¹ +1-905-812-8099 or FAX: +1-905-812-7807
1-800-624-9857

European Support Services

For European customer support, dial the toll-free number for your specific country for presales support, technical support, SeaFAX and warranty repair.

If your country is not listed here, dial our European call center at +31-20-316-7222 from 8:30 A.M. to 5:00 P.M. (European central time) Monday through Friday. The European call center is located in Amsterdam, The Netherlands.

Call Center

Austria	0 800-20 12 90
Belgium	0 800-74 876
Denmark	80 88 12 66
France	0 800-90 90 52
Germany	0 800-182 6831
Ireland	1 800-55 21 22

¹Authorized Service Centers

Italy	1 677 90 695
Netherlands	0 800-732 4283
Norway	800-113 91
Poland	00 800-311 12 38
Spain	900-98 31 24
Sweden	0 207 90 073
Switzerland	0 800-83 84 11
Turkey	00 800-31 92 91 40
United Kingdom	0 800-783 5177

SeaBOARD

Germany +49-89-1409331

Fax Services—All European Countries

Presales/Technical Support/Warranty Repair +31-20-653-3513

Africa/Middle East Support Services

For presales, technical support, warranty repair and FAX services in Africa and the Middle East, dial our European call center at +31-20-316-7222 from 8:30 a.m. to 5:00 p.m. (European central time) Monday through Friday, or send a FAX to +31-20-653-3513. The European call center is located in Amsterdam, The Netherlands.

Asia/Pacific East Support Services

Technical Support

Australia	+61-2-9725-3366	FAX: +61-2-9725-4052
Hong Kong	+852-2368 9918	FAX: +852-2368 7173
Japan	—	FAX: +81-3-5462-2979
Singapore	+65-488-7584	FAX: +65-488-7528
Taiwan	+886-2-2514-2237	FAX: +886-2-2715-2923

SeaFAX

Australia +61-2-9756-5170

Warranty Repair

Japan +81-3-5462-2904 FAX: +81-3-5462-2979

Asia/Pacific and +65-485-3595 FAX: +65-488-7503

Australia

General description

Barracuda 18LP SCSI disc drives are high-speed, random-access digital-data storage devices.

The drive is a component for installation in an enclosure designed for the drive. This is often a rack within the system or an external enclosure designed to house one or more disc drives or other peripheral units. In either case, the disc drive must receive adequate cooling (refer to “Providing adequate cooling”) and it must be sufficiently grounded and shielded from emissions. The *Barracuda 18LP Product Manual* (part number 77767526) contains guidelines for a properly designed enclosure.

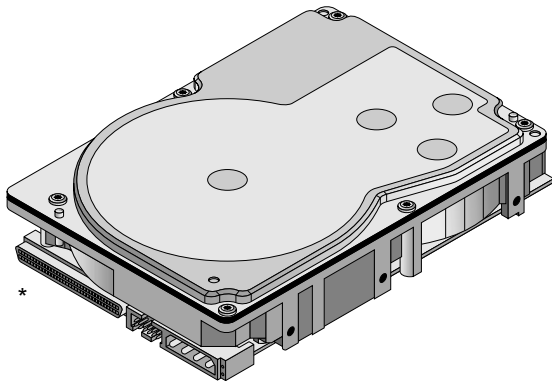

*Model “LW” version with 68-pin SCSI I/O connector

Figure 1. Barracuda 18LP family drive

Table 1. Drive characteristics

Interface	UltraSCSI [1]	
Capacity	Formatted [2]	Max. data blocks [2]
ST39175	9.1 Gbyte [2]	10F59C7h [2]
ST318275	18.2 Gbyte [2]	21EB38Fh [2]
Recording		
Cylinders (user)	11,721	
Read/write data heads		
ST39175	5	
ST318275	10	
Access time [3]		
Average read	6.9 msec	
Average write	7.7 msec	
Disk rotation		
RPM	7,200 r/min	
Average latency	4.17 msec	
Internal transfer rate (variable with zone)		
ST39175	137–240 Mbits/sec	
ST318275	137–240 Mbits/sec	
Maximum synchronous SCSI transfer rate		
LW/LC	80 Mbytes/sec	

[1] Operated according to SCSI-2 and SCSI-3 protocols. Referred to also as “SCSI Fast-20” and “Fast-40.”

[2] Read data capacity. Add one for total capacity. Standard factory units are formatted 512 data bytes per sector with spare tracks reserved for reallocating bad sectors.

[3] Includes controller overhead.

Table 2. DC power requirements (Amps), multimode (SE/LVD)

	ST39175LW/LC		ST318275LW/LC	
	+5V	+12V	+5V	+12V
Voltage	+5V	+12V	+5V	+12V
Regulation [5]	±5%	±5%[2]	±5%	±5%[2]
Avg. idle current DC \bar{X} [1]	0.75	0.35	0.75	0.5
Max. starting current (peak DC) [3]	1.0	1.3	1.05	1.6
(peak AC) [3]	—	2.4	—	2.4
Delayed motor start (max) [1][4]	0.65	0.05	0.65	0.05
Peak operating current				
Typical DC \bar{X} [1][6]	1.0	0.7	1.05	0.8
Maximum DC [1]	1.3	1.4	1.4	1.5
Maximum (peak)	1.7	2.1	1.7	2.4

- [1] Measured with an average reading DC ammeter. Instantaneous +12V current peaks will exceed these values.
- [2] A –10% droop is permissible during initial start of the spindle but must return to ±5% before reaching 7,200 RPM. The ±5% must be maintained after the drive signifies that its power-up sequence has been completed and that the drive is able to accept selection by the host initiator.
- [3] See the +12V current profile in the *Barracuda 18LP Product Manual* (publication number 77767526).
- [4] This condition occurs when the Motor Start option is enabled and the drive has not yet received a Start Motor command.

- [5] See “Conducted noise immunity” in the *Barracuda 18LP Product Manual*. The specified voltage tolerance is inclusive of ripple, noise, and transient response.
- [6] Operating condition is defined as random seek read operations with a block count of 64.

General Notes from Table 2.

1. Minimum current loading for each supply voltage is not less than 4% of the maximum operating current shown.
2. Use separate ground returns for +5V and +12V supplies.
3. Where power is provided to multiple drives from a common supply, carefully consider individual drive power requirements. Where multiple units are powered on simultaneously, be sure the peak starting current is available to each device.

Table 3 shows the nominal (no tolerance specified) dimensions and weight of the drive.

Table 3. Dimensions of the drive

	inches	mm
Height	1.00	25.4
Width	4.00	101.6
Depth	5.75	146.05
Weight	1.5 pounds (0.589 kilograms)	

Initial setup information

The general information beginning on this page applies to all of the Barracuda 18LP drive models. After reading the general information topics, refer to the appropriate drive-specific section listed below for additional information about configuring and installing your particular model.

Drive models		Page
ST39175LW	ST318275LW	40
ST39175LC	ST318275LC	45

General information

The following general information topics are discussed:

- SCSI ID jumpers
- Drive termination
- Terminator power
- Interface drivers and data path width notes
- Other applicable jumper options
- Providing adequate cooling
- Mounting the drive and connecting cables¹
- Formatting the drive

¹This mounting procedure does not apply to “LC” model drives. To mount an “LC” drive, plug the drive into the system’s single connector attachment (SCA) position on the system’s back panel.

SCSI ID jumpers

Each device on the SCSI chain must have a unique SCSI ID. The host system's SCSI controller usually uses the ID that has the highest priority interrupt in the SCSI I/O system. This is always ID7. ID0 is lowest priority in an 8-bit I/O system. ID8 is lowest priority in a 16-bit I/O system. The lower priority SCSI IDs are normally used for other SCSI devices such as this Barracuda disc drive.

Note. Most SCSI controllers (host adapters) allow you to skip a SCSI ID. For example, you can have ID0, ID1, and ID3 (skipping ID2). Other controllers do not allow this so be sure to refer to your system or controller user's manual for details about its requirements for proper SCSI device installation.

Note. This drive is a SCAM (SCSI Configured Auto Magically) compliant drive. If the system into which you are installing this drive requires SCAM compliant drives, you do not need to be concerned about the drive ID jumper settings, as the system automatically assigns your new drive the ID it wants it to have. The system may or may not use the existing drive ID jumper settings. Setting the drive ID doesn't hurt anything, but is not necessary in a SCAM compliant system.

Most Barracuda disc drives are factory set with the SCSI ID set at 0. To change the SCSI ID, refer to the appropriate drive section for your model.

If, after completing the installation process, the drive's LED does not show on/off activity when the host is trying to communicate with the drive, a duplicate SCSI ID may be the problem. If this is

the case, change the ID so that each device on the SCSI chain has its own unique ID. Also check your system or controller user's manual to ensure that you have not violated its SCSI ID numbering recommendations.

Drive termination

If you are installing a Barracuda drive in a system that has other SCSI devices installed, terminate only the end devices on the SCSI chain. A SCSI "device" is any disc drive, scanner, tape backup unit, or other piece of hardware connected to your system using the SCSI bus.

The top example in Figure 2 shows an internal hard disc at one end of the SCSI bus with the SCSI controller at the other end (both are terminated). The bottom example shows two additional SCSI devices connected externally—this means the SCSI controller is no longer on the end of the SCSI chain and should not be terminated.

Note. Some controllers prefer to remain terminated even if they are in the middle of the chain. Also, some controllers treat the internal and external chains as separate logical buses. This means you may need to terminate both the first and last devices on both logical buses to achieve proper termination. If necessary, refer to your system or controller documentation to see how this is handled in your particular system.

For information about how to terminate your drive, refer to the appropriate drive-specific section.

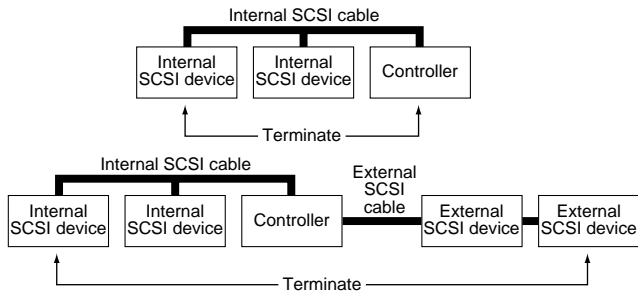

Figure 2. SCSI bus termination

Terminator power

You usually will not need to change this option and can normally leave the drive configured as it was shipped from the factory. For information about how to change the terminator power option on your drive, refer to the appropriate drive-specific section.

I/O circuits and data path widths

Note. Make sure your system I/O controller circuit board has the proper I/O circuits to communicate with this drive. You may have to replace your old controller with a newer one having the proper I/O circuits. The following paragraphs and tables will help you to know whether you want to operate the drive I/O circuits in single-ended (SE) mode or low voltage differential (LVD) mode. If your old I/O controller operated the I/O circuits in differential mode, chances are it was high voltage differential mode (HVD).

This drive must not be operated with that kind of controller. This drive can operate with older SE controllers, however.

- “LW” and “LC” models use SCSI multimode I/O circuits. Multimode circuits operate either in single-ended mode or low voltage differential mode. No high voltage differential devices should be connected in the I/O daisy chain with “LW” or “LC” model drives. The state of the I/O “DIFFSNS” line determines whether the devices on the SCSI bus operate their I/O circuits in single-ended or low voltage differential mode. The host device on the SCSI bus operates the “DIFFSNS” line. However, the **SE** jumper on J2 forces “DIFFSNS” to nominal ground (see Figure 12). The host device cannot override the **SE** jumper. If “DIFFSNS” is at nominal ground (0V to .6V), all of the bus receivers/drivers operate in single-ended mode. If “DIFFSNS” is between .7V and 1.9V, all bus receiver/drivers operate in low voltage differential (LVD) mode.
- “LC” and “LW” models have a “wide” (16-bit) SCSI data bus rather than the standard (non-wide) 8-bit SCSI data bus; however, you can use these wide drives on a standard (non-wide) 8-bit data bus. However, the unused lines must be terminated the same as the used lines.

Figures 3a, 3b, and 3c show typical drive connections. The following tables list the maximum cable lengths and number of devices allowed on a daisy-chain cable for I/O data transfer rates shown.

Note. For LVD operation, twisted pair cables are recommended. For LVD Fast-40 operation, twisted pair cables are *strongly* recommended. For Fast-80 operation, twisted pair cables are *required*.

Table 4a. Cable characteristics for single-ended I/O circuits

Number of attached SCSI devices	Maximum distance between terminators (meters) [1] [3]			
	Fast-5	Fast-10	Fast-20	Fast-40
1 to 4 maximum capacitance (25 pF) SCSI devices	6	3	3	N/A
5 to 8 maximum capacitance (25 pF) SCSI devices	6	3	1.5	N/A
9 to 16 maximum capacitance (25 pF) SCSI devices	6	3	[2]	N/A

- [1] For environments where all elements of the bus (cables, device interfaces, environmental noise and other parameters) are controlled to be better than minimally required, it may be possible to extend the path length and device count.
- [2] Extending the device count beyond eight requires specification control beyond the minimum specified in the ANSI T10/1142D document. It is recommended that the devices be uniformly spaced between terminators with the end devices located as close as possible to the terminators.
- [3] Values specified by data rate shall apply even if a slower data rate is negotiated.

Table 4b. Cable characteristics for differential I/O circuits

Interconnect	Maximum distance between terminators (meters) [1] [3]			
	Fast-5	Fast-10	Fast-20	Fast-40
Point-to-point interconnect (2 devices)	25	25	25	25 [2]
Daisy-chain interconnect (up to 16 devices) [4]	15	15	15	12

- [1] For environments where all elements of the bus (cables, device interfaces, environmental noise and other parameters) are controlled to be better than minimally required, it may be possible to extend the path length and device count.
- [2] SCSI devices shall be within a stub length of the termination (.1 meter).
- [3] Values specified by data rate shall apply even if a slower data rate is negotiated.
- [4] Loads spaced at least 8 inches (20.3 cm) apart (refer to SCSI EPI T10/1143D specification).

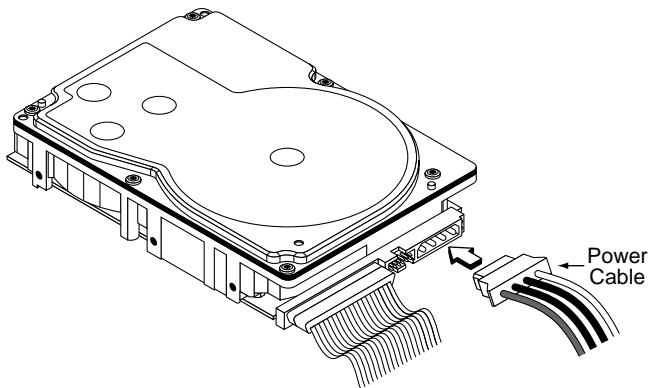
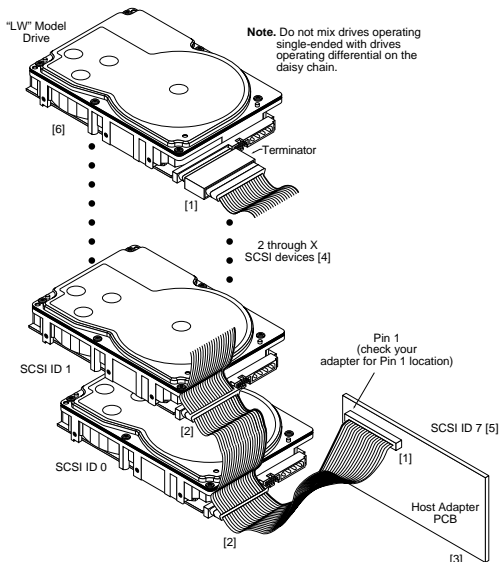
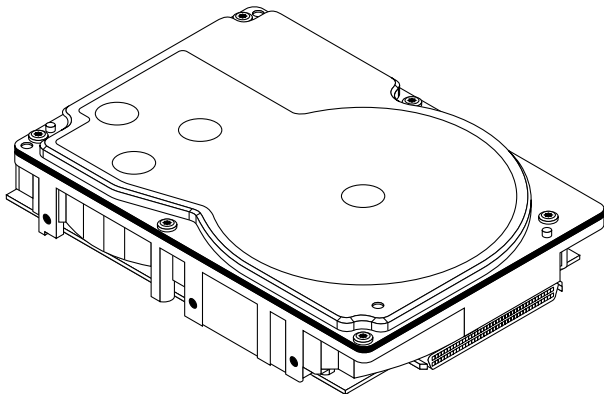

Figure 3a. Sixty-eight pin connection to “LW” model drive



- [1] Closed end type 68 pin connector used. Terminator required.
- [2] Open end type (in-line application) connector used. No terminator.
- [3] Host need not be on the end of the daisy chain. Another device can be on the end with the terminator, the host having no terminator.
- [4] Total interface cable length must not exceed that specified in ANSI Standard X3T10/1142D (including host adapter/initiator). The cable length restriction limits the total number of devices allowed.
- [5] SCSI ID7 has highest arbitration priority. For "LW" models, priority is ID7 to ID0, then ID15 to ID8 (ID 8 very lowest).
- [6] Last drive on the daisy chain.

Figure 3b. Multiple-drive "LW" model connection to host adapter



Note. This drive model plugs directly into a backplane connector and therefore uses no cables.

Figure 3c. Drive model “LC” with single 80-pin I/O and power connector

Providing adequate cooling

The enclosure design must ensure adequate cooling for the drive. The maximum ambient air temperature around the drive should not exceed 50°C. However, to achieve maximum reliability, the ambient temperature should be about 15°C below this value most of the time.

The drive's product manual (77767526) describes how to evaluate the air-flow design. The evaluation consists of ensuring that the case temperature of certain critical components remains within acceptable limits during drive operation.

We recommend orienting the drive or directing the air flow in a way that creates the least amount of air-flow resistance while providing air flow above the circuit boards and around the head and disc assembly (HDA). Also, choose the shortest possible path between the air inlet and exit. This minimizes the distance traveled by air that is heated by the drive and by other nearby heat sources.

Figure 4 shows two design approaches with one or more fans used to generate air flow. The air-flow patterns can be created by the fans either pushing or drawing air. The overall flow pattern can be directed from front to back, back to front, or side to side.

Kühlung des Systems

Die Gehäusekonstruktion muß eine ausreichende Kühlung des Laufwerkes gewährleisten. Die Umgebungstemperatur darf maximal 50°C betragen.

Die Produkthandbuch Barracuda 18LP (Dokument 77767526) enthalten Anweisungen zur Beurteilung der Luftstromkonstruktion. Die Beurteilung muß sicherstellen, daß sich die Gehäusetemperatur bestimmter kritischer Komponenten bei Laufwerkbetrieb innerhalb zugelassener Grenzen hält.

Wir empfehlen, das Laufwerk so zu orientieren oder den Luftstrom so zu lenken, daß der geringste Luftstromwiderstand erzeugt wird und gleichzeitig ein Luftstrom über den Platinen und um die Kopf- und Festplatteneinheit (HDA) gegeben ist. Wählen Sie einen möglichst kurzen Weg zwischen Lufteinlaß und -auslaß. Dadurch wird die Strecke, die die vom Laufwerk und anderen nahegelegenen Hitzequellen aufgewärmte Luft zurücklegt, auf ein Minimum beschränkt.

Abbildung 4 zeigt zwei Konstruktionsmöglichkeiten, bei denen ein oder mehrere Lüfter den Luftstrom erzeugen. Der Luftstromverlauf wird durch die Lüfter gesteuert, die entweder Luft einblasen oder abziehen. Generell kann der Luftstrom entweder von vorne nach hinten oder von hinten nach vorne verlaufen.

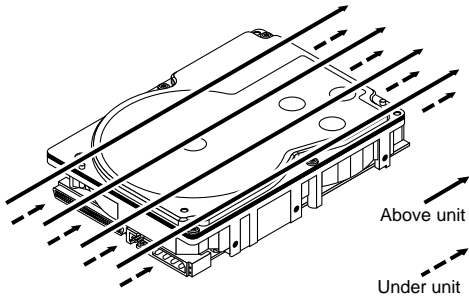

Note. Air flows in the direction shown (front to back) or in reverse direction (back to front)

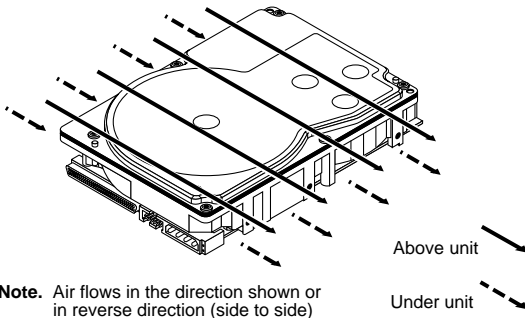

Note. Air flows in the direction shown or in reverse direction (side to side)

Figure 4. Suggested air flow
Abbildung 4. Empfohlener Luftstromverlauf

Mounting the drive and connecting cables

Do not touch the connector pins or any components on the control board without observing static-discharge precautions. Always handle the drive by the frame only.

The drive may be mounted in any orientation (horizontally, vertically, and any combination thereof); however, you must ensure that the drive receives adequate air flow for cooling.

1. Mount the drive to the host system's chassis using four 6-32 UNC screws. Two mounting holes are in each side of the drive and there are four mounting holes in the bottom of the drive.

The maximum length that the screws should extend into the chassis mounting holes is 0.15 inch (3.81 mm), measured from the outer surface of the chassis. Tighten the screws down evenly. Do not over-tighten or force the screw if it does not seem to screw in easily, because this means the threads are not properly aligned. In this case, back the screw out and try again.

Installation des Laufwerkes und Anschluß der Kabel

Beachten Sie beim Handhaben und Anfassen der Anschlußstifte und Komponenten die Vorsichtsmaßnahmen zur Verhinderung statischer Aufladung. Fassen Sie das Laufwerk nur am Rahmen an.

Das Laufwerk kann in beliebiger Orientierung (horizontal, vertikal oder schräg) installiert werden; jedoch muß dafür gesorgt werden, daß ein ausreichender Luftstrom zur Kühlung des Laufwerkes vorhanden ist.

1. Befestigen Sie das Laufwerk mit vier 6-32-UNC-Schrauben am Gehäuse des Host-Systems. Die beiden Seiten des Laufwerkes sind mit jeweils zwei Befestigungslöchern versehen, die Unterseite des Laufwerkes weist vier weitere Befestigungslöcher auf.

Gemessen von der Außenfläche des Gehäuses dürfen die Schrauben maximal 3,81 mm in die Befestigungslöcher des Gehäuses hineinragen. Die Schrauben müssen gleichmäßig, jedoch nicht zu fest, angezogen werden. Wenn sich eine Schraube nicht ohne Widerstand einschrauben läßt, sind die Gewinde nicht korrekt aneinander ausgerichtet. In diesem Fall die Schraube nicht in das Gewindeloch forcieren, sondern die Schraube herausnehmen und erneut in das Gewindeloch einführen.

-
2. Verify that all connections between the drive and the host system are correctly installed.

-
2. Prüfen Sie, ob alle Verbindungen zwischen dem Laufwerk und dem Host-System korrekt hergestellt sind.

-
3. Verify that you have correctly installed jumpers.

-
3. Stellen Sie sicher, daß die Kennungsbrücken installiert sind.

-
4. Connect the SCSI cable into the drive's SCSI connector. Take care not to stretch or crimp this cable, and do not block the system's cooling air flow with the cable.

The drive receives DC power through a 4-pin connector mounted next to the SCSI connector. The output of a power supply must meet SELV (safety extra low voltage) as defined in IEC 950. Figure 5 provides the pin information for

the DC power connector. To connect the DC power cable to the drive, simply insert the cable end into the drive's DC power connector.

4. Schließen Sie das SCSI-Kabel an den SCSI-Steckverbinder des Laufwerkes an. Das Kabel darf nicht gedehnt oder gedrückt werden und es darf den Luftstrom zur Kühlung des Systems nicht behindern.

Das Laufwerk wird über einen 4-poligen, neben dem SCSI-Anschluß befestigten Steckverbinder mit Gleichstrom versorgt. Der Ausgang eines Netzteils muß SELV (safety extra low voltage) nach IEC 950 entsprechen. Abbildung 5 zeigt die Steckerbelegung für den Gleichstromanschluß. Zum Anschluß des Gleichstromkabels an das Laufwerk das Kabelende in den Gleichstromanschluß des Laufwerkes stecken.

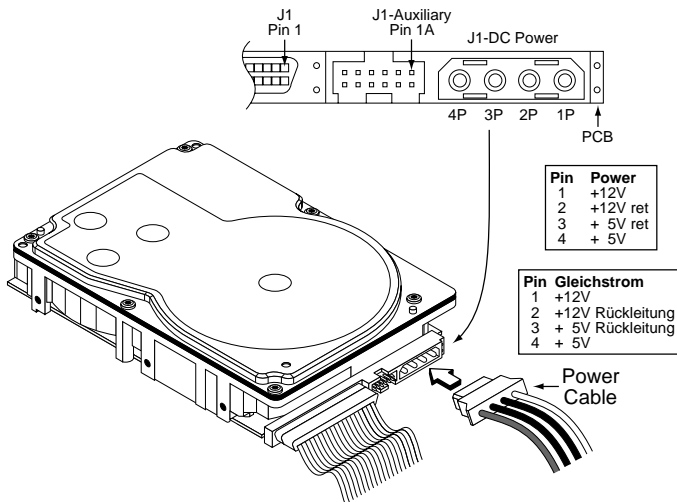

Figure 5. DC power connector
Abbildung 5. Gleichstromanschluß

Note. Signal ground on the power control board (PCB) and the head and disc assembly (HDA) are connected together in this drive and you cannot separate them. The equipment in which you have mounted the drive is connected directly to the HDA and PCB without electrically isolating shock mounts. Maximizing the conductive contact area between HDA ground and system ground may reduce radiated emissions.

If you do not want the system chassis to be connected to the HDA/PCB ground, you must provide a nonconductive

(electrically isolating) method of mounting the drive in the host system. This may increase radiated emissions and is the system designer's responsibility.

Hinweis:

Die Signalerde auf der Stromregelungskarte (PCB) und der Kopf- und Festplatteneinheit (HDA) sind in diesem Laufwerk miteinander verbunden und können nicht getrennt werden. Das Gerät, in das Sie das Laufwerk eingebaut haben, ist ohne elektrisch isolierende Stoßdämpfer direkt an die HDA und PCB angeschlossen. Die elektromagnetische Strahlung kann reduziert werden, indem Sie eine möglichst große leitende Kontaktfläche zwischen der HDA-Erdung und der Systemerdung vorsehen.

Wenn Sie das Systemgehäuse nicht an die HDA/PCB-Erdung anschließen wollen, müssen Sie das Laufwerk auf nichtleitende Weise (galvanisch isoliert) im Host-System einbauen. Die daraus u.U. resultierende verstärkte elektromagnetische Strahlung fällt in den Zuständigkeitsbereich des Systemdesigners.

-
5. Replace the host system's cover.
-
5. Setzen Sie das Gehäuseoberteil des Host-Systems wieder auf.

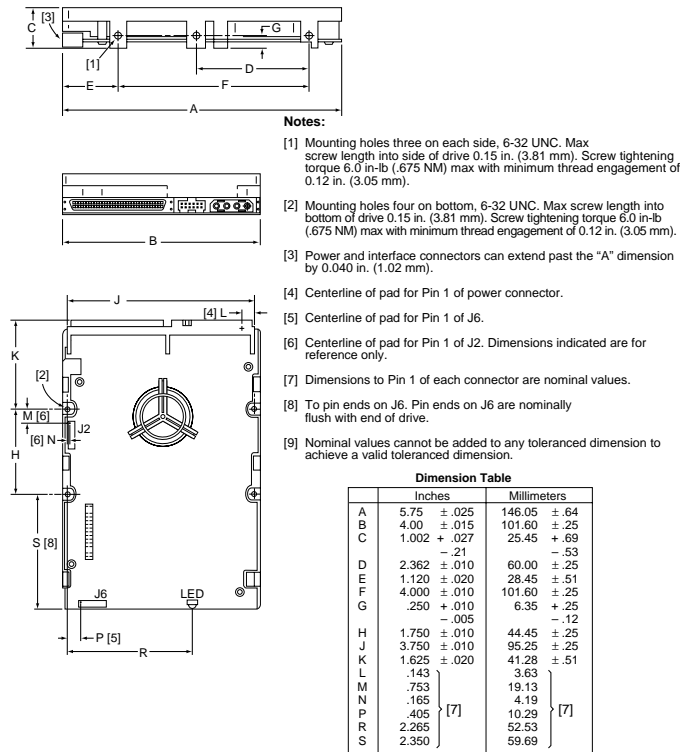

Figure 6. Mounting configuration dimensions

Formatting the drive

The drive has been low level formatted at the factory. You do not need to perform another low level format on this drive unless you decide to perform certain diagnostics through the host adapter.

If you do decide to perform a low level format, do not abort the format as this is likely to make the drive inoperable. Also, it is a good idea to protect against power failure or other power interruptions during the format. Keep in mind that it may take up to one hour per gigabyte to low level format the drive. Do not reboot or otherwise disrupt the process.

Warning. Formatting a drive erases all user data. Be sure that you understand this principle before formatting any hard disc drive. It is not necessary to format a drive that previously has been used to store data, unless your intention is to erase all user data.

Note. Seagate is not responsible for lost user data.

1. Turn on DC power.
2. Boot the system from a system floppy disc or from a previously installed hard disc drive if there is one.
3. Format the disc drive. Barracuda 18LP disc drives are designed to operate with a variety of operating systems. Please refer to your system or SCSI controller manual for information about formatting and setting up the drive. Some quick desktop system notes are provided below.

Quick reference desktop system notes

Note. Refer to your system or utility manual for detailed instructions)

-
- DOS. Set the drive type in CMOS to “Zero,” “None,” or “No hard drive installed.” Use FDISK.EXE and FORMAT.EXE. Systems that have operating system Windows 95 release 950B or later do not need to partition the drive.
 - Macintosh. Use a third-party drive utility (Apple’s HD Setup utility only works with drives having special Apple firmware).

LW drives

Setting the SCSI ID jumpers

Use the J6 jumper block to set the SCSI ID (Figure 7). To change the SCSI ID, install jumpers on the appropriate pins as shown in the illustration. Optional connections to switching circuits in host equipment are provided on J1 auxiliary to set the SCSI ID (see Figure 8).

Terminating the drive

“LW” model drives do not have internal terminators or any other way of adding internal termination to the drive. External termination for these drives must be supplied by the host equipment.

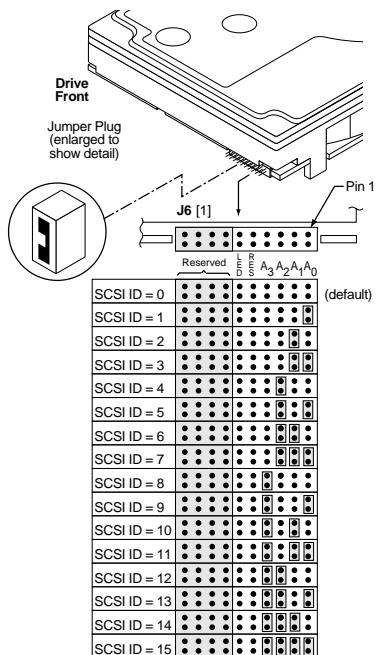

Figure 7. Setting the SCSI ID on model LW drives

LW drives

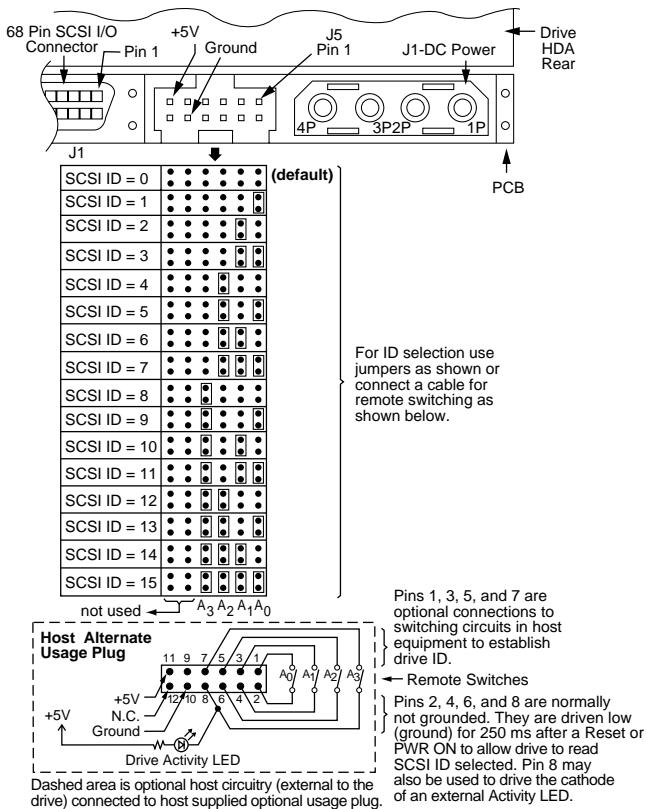
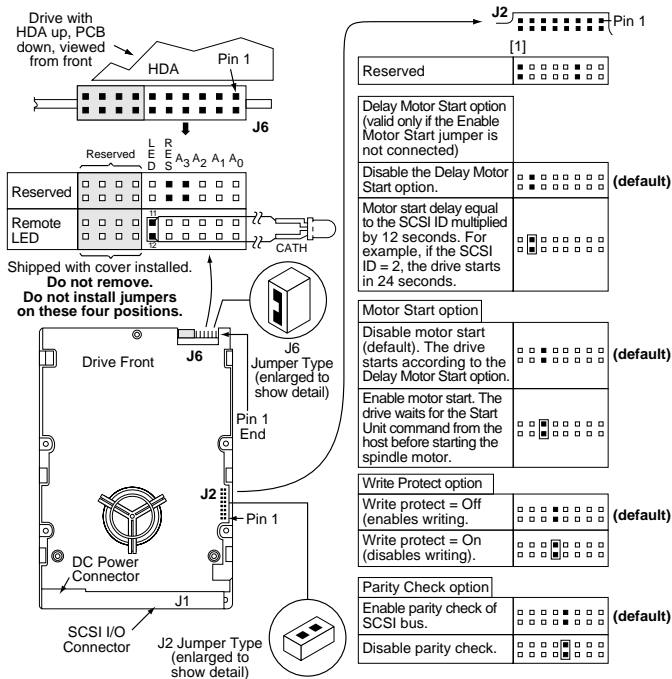

Figure 8. Using J5 connector for model “LW” drive alternate ID select and LED connection

Other applicable jumper options

Other option jumpers are available as illustrated in Figures 9 and 10.



[1] See Figure 10 for this jumper position option for "LW" drives.

Figure 9. Additional jumper options for "LW" drives

LW drives

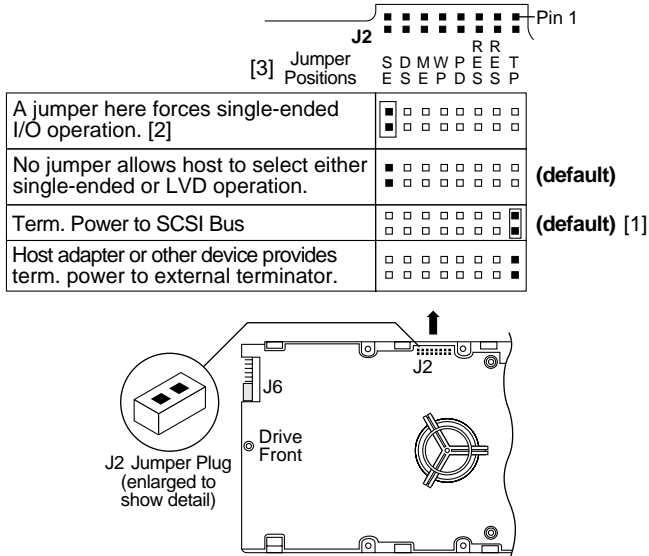

[1] TP not used on “LC” drive

[2] Jumper not to be installed for “LW” operation

[3] Jumper position names shown here are not marked on the PCB. They are shown here for reference only.

Figure 10. Additional jumper option for “LW” drives

Setting the SCSI ID jumpers

The SCSI ID for “LC” model drives is normally set over the SCSI bus by the host system using connector contacts 39 (ID0), 40 (ID2), 79 (ID1), and 80 (ID3). Users need not install jumpers to select SCSI ID.

Terminating the drive

“LC” model drives do not have internal terminators or any other way of adding internal termination to the drive. External termination for these drives must be supplied by the host equipment.

LC drives

	J2	Pin 1
	S D M W P E E E E S E P D S S S	R R R R R R
Delay Motor Start option	Jumper Positions [1]	
The host system has complete control over motor start functions. Do not install a jumper on these pins.	<input type="checkbox"/> <input type="checkbox"/> <input type="checkbox"/> <input type="checkbox"/> <input type="checkbox"/> <input type="checkbox"/> <input type="checkbox"/> <input type="checkbox"/>	(default)
Enable Motor Start option		
The host system has complete control over motor start functions. Do not install a jumper on these pins.	<input type="checkbox"/> <input type="checkbox"/> <input checked="" type="checkbox"/> <input type="checkbox"/> <input type="checkbox"/> <input type="checkbox"/> <input type="checkbox"/> <input type="checkbox"/>	(default)
Write Protect option		
Write protect = Off (enables writing)	<input type="checkbox"/> <input type="checkbox"/> <input type="checkbox"/> <input checked="" type="checkbox"/> <input type="checkbox"/> <input type="checkbox"/> <input type="checkbox"/> <input type="checkbox"/>	(default)
Write protect = On (disables writing)	<input type="checkbox"/> <input type="checkbox"/> <input type="checkbox"/> <input type="checkbox"/> <input checked="" type="checkbox"/> <input type="checkbox"/> <input type="checkbox"/> <input type="checkbox"/>	
Parity Check option		
Enable parity check of SCSI bus.	<input type="checkbox"/> <input type="checkbox"/> <input type="checkbox"/> <input type="checkbox"/> <input checked="" type="checkbox"/> <input type="checkbox"/> <input type="checkbox"/> <input type="checkbox"/>	(default)
Disable parity check.	<input type="checkbox"/> <input type="checkbox"/> <input type="checkbox"/> <input type="checkbox"/> <input type="checkbox"/> <input checked="" type="checkbox"/> <input type="checkbox"/> <input type="checkbox"/>	

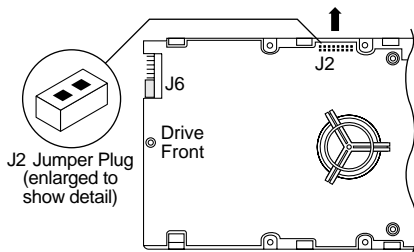

[1] Jumper position names shown here are not marked on the PCB. They are shown here for reference only.

Figure 11. Jumper options for “LC” drives

Single-ended/low-voltage-differential selection

The **SE** jumper, when installed on J2, forces the drive I/O circuits and all other devices on the SCSI bus to operate in the single-ended (SE) mode. When the **SE** jumper is not on, the SCSI I/O can operate in either single-ended or low-voltage differential (LVD) mode, depending on which mode the host device has selected using the “DIFFSNS” I/O line. The **SE** jumper should not be installed unless the system documentation specifically states that it should be installed. The I/O bus can transfer data at a much higher data rate in the LVD mode, but the system must be designed to accommodate a higher data rate.

LC drives

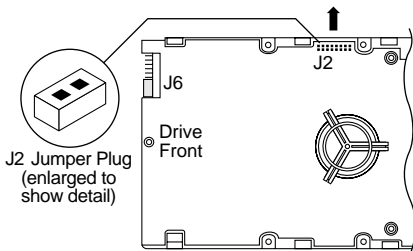
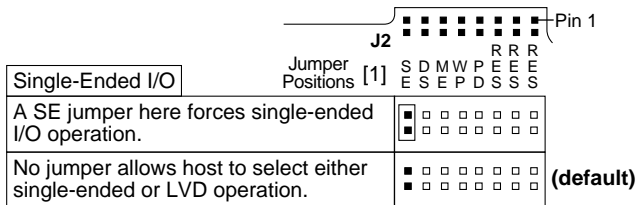

[1] Jumper position names shown here are not marked on the PCB. They are shown here for reference only.

Figure 12. Additional jumper options for “LC” drives



Seagate Technology, Inc.

920 Disc Drive, Scotts Valley, CA 95066-4544, USA

Publication Number: 77767527, Rev. B, Printed in USA